

# LRA 12235L A

## LINEAR RESONANT ACTUATOR

### CONTENT

1. Specifications
2. Drawing
3. Test Setup
4. Acceleration Characteristics
5. Reliability Test
6. Packing
7. Notice
8. History Change Record

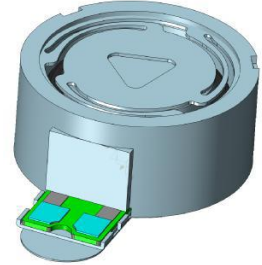

## 1. SPECIFICATIONS

Parameter	Unit	Conditions / Description	MIN	TYP	MAX
Rated Voltage	Vrms			1.5	
Operating Voltage	Vrms		0.3		1.8
Resonance Frequency	Hz		188	235	282
Resistance	$\Omega$	At 20°C	19.2	24	28.8
Acceleration	Grms	At 100g load, 1.5Vrms	0.9		
Rise Time	ms	0 → 90%, At 100g load, 1.5Vrms, 235Hz			60
Break Time	ms	100 → 10%, At 100g load, 1.5Vrms, 235Hz			90
Polarity		Positive voltage to (+), the magnet bowl moves forward			
Contact				TAB	
Packaging				TRAY	
Operating Temperature	°C		-40		+85
Storage Temperature	°C		-40		+95
Weight	g			2	

### Remark:

Environmental Conditions

Standard conditions for inspection and measurement:

Temperature: +15~+35°C, Humidity: 45~85% RH (no condensation of moisture)

When a judgment under the standard condition raises doubts, the following conditions apply:

Temperature: +18~+22°C, Humidity: 50~60% RH (no condensation of moisture)

DESIGNED BY	Rabea Richter	DATE	2021.09.09	PART NO.	LRA 12235L A	INDEX	A
RELEASED BY	Anouschka Esselun	DATE	2021.09.14				
CHANGED BY	Rabea Richter	DATE	2023.05.12				
DRAWING NO.	444484814						

## LRA 12235L A

LINEAR RESONANT ACTUATOR

### 2. DRAWING

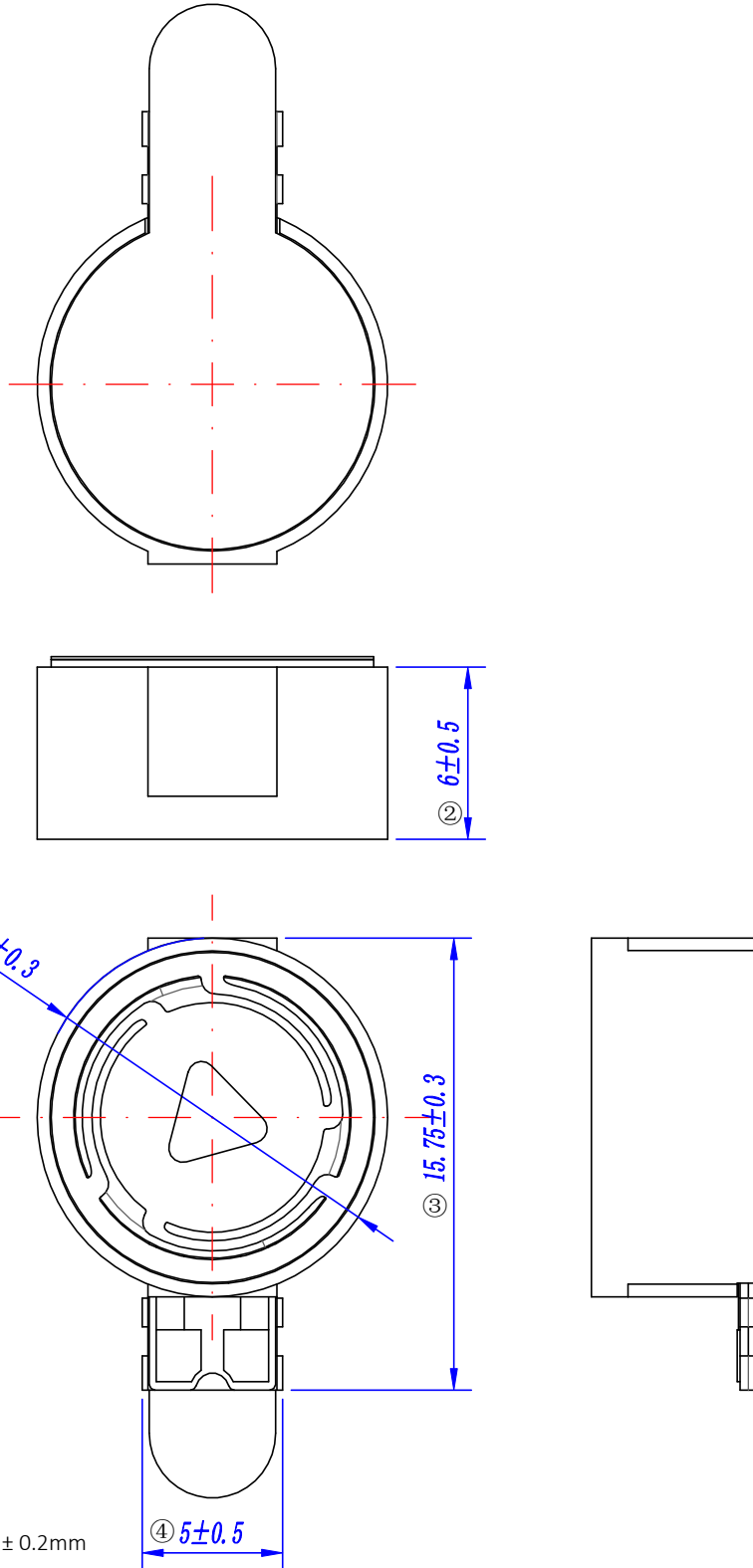

Unit: mm

Tolerance:  $\pm 0.2\text{mm}$

DESIGNED BY	Rabea Richter	DATE	2021.09.09	PART NO.	LRA 12235L A	INDEX	A
RELEASED BY	Anouschka Esselun	DATE	2021.09.14				
CHANGED BY	Rabea Richter	DATE	2023.05.12				
DRAWING NO.	444484814						

## LRA 12235L A

LINEAR RESONANT ACTUATOR

### 2.1 PART LIST

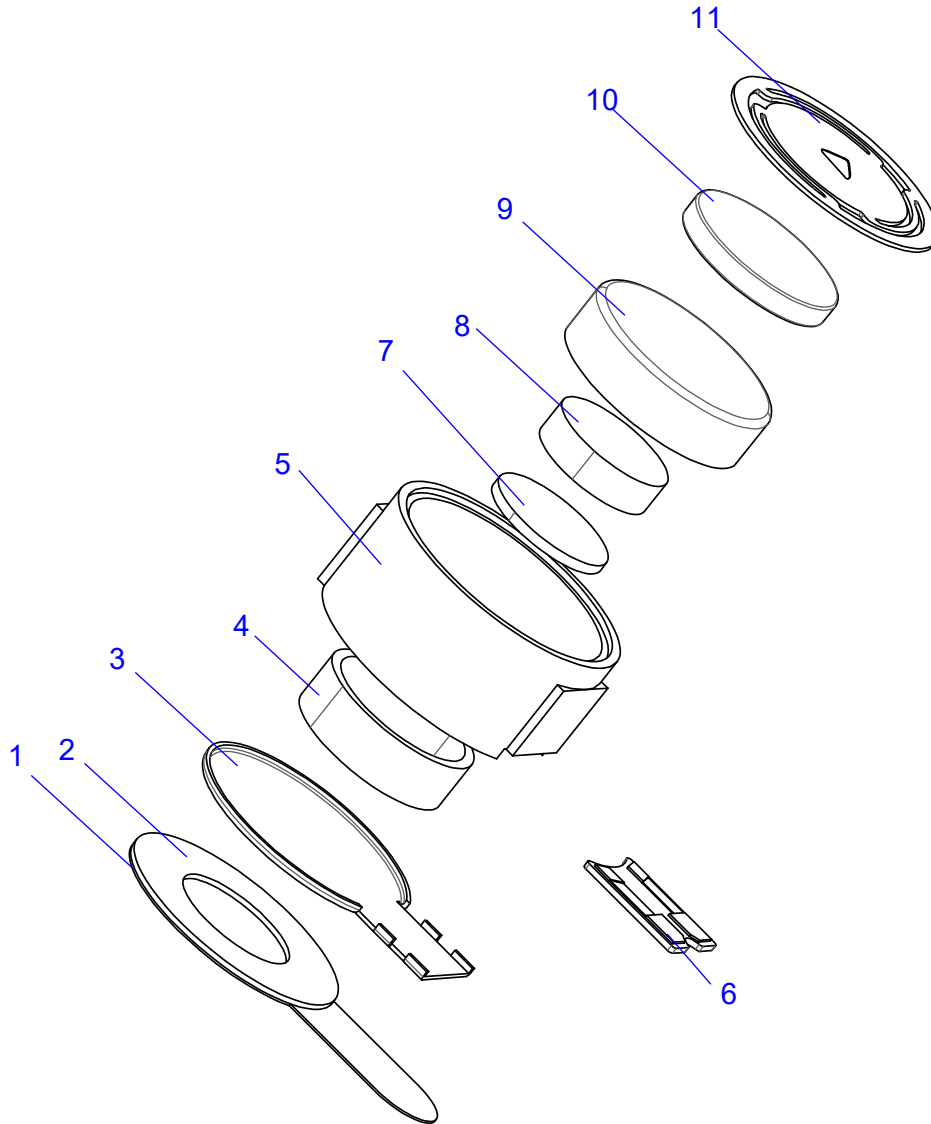

No	Part Name	Material
1	Release Liner	Paper
2	3M adhesive	3MVHB F9473PC
3	Cover Plate	SUS
4	Voice Coil	∅0.065
5	Plastic Housing	PBT GF30
6	PCBA	FR4
7	Pole Piece	SPCC
8	Magnet	NdFeB
9	Magnet Bowl	SPCC
10	Mass	SUS
11	Spring	SUS

DESIGNED BY	Rabea Richter	DATE	2021.09.09	PART NO.	LRA 12235L A	INDEX	A
RELEASED BY	Anouschka Esselun	DATE	2021.09.14				
CHANGED BY	Rabea Richter	DATE	2023.05.12				
DRAWING NO.	444484814						

## LRA 12235L A

LINEAR RESONANT ACTUATOR

### 3. TEST SETUP

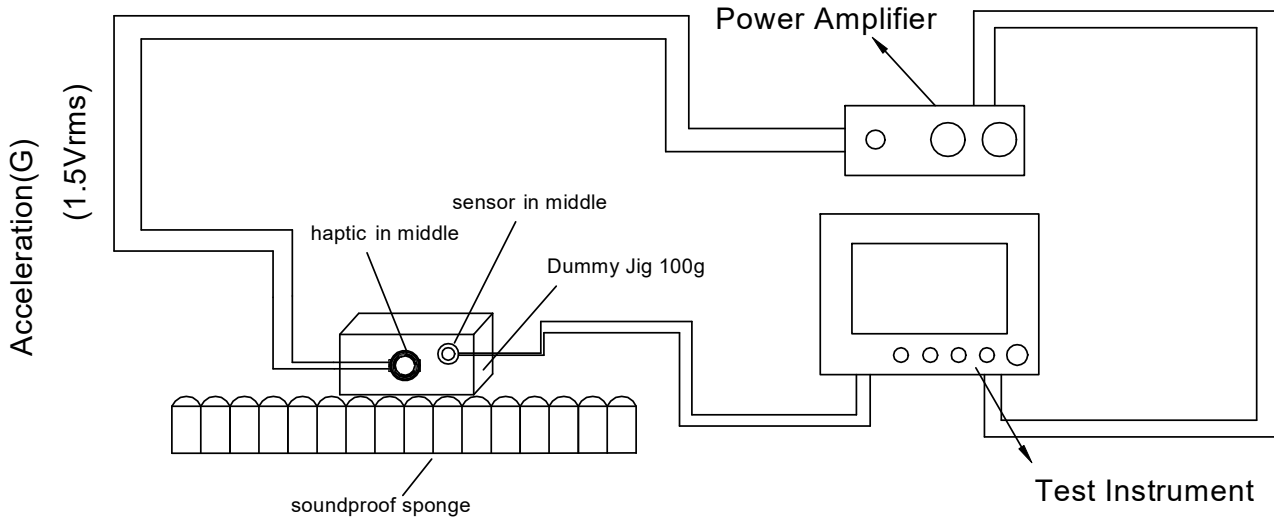

### 4. ACCELERATION CHARACTERISTICS

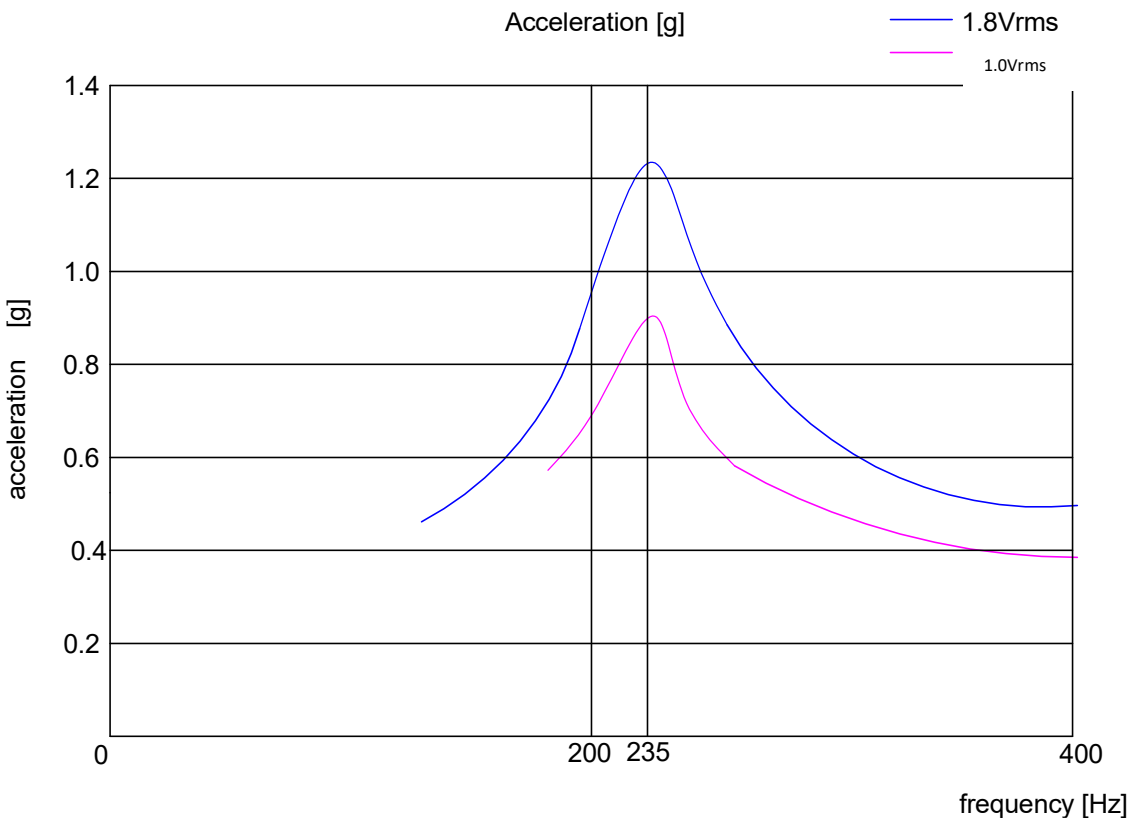

DESIGNED BY	Rabea Richter	DATE	2021.09.09	PART NO.	LRA 12235L A	INDEX	A
RELEASED BY	Anouschka Esselun	DATE	2021.09.14				
CHANGED BY	Rabea Richter	DATE	2023.05.12				
DRAWING NO.	444484814						

# LRA 12235L A

## LINEAR RESONANT ACTUATOR

### 5. RELIABILITY TEST

#### 5.1 High Temperature Storage Test

Temperature +95 ±2°C  
Duration 1000 hours

#### 5.2 Low Temperature Storage Test

Temperature -40 ±2°C  
Duration 500 hours

#### 5.3 Thermal Shock Test

Temperature -40~+85°C  
Duration 1000 hours

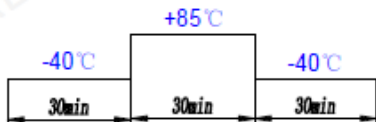

#### 5.4 Temperature Cycle Test

Cycles 80

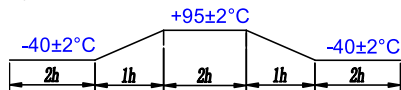

#### 5.5 Damp Heat Test

Temperature +85 ±2°C  
Relative Humidity 85 ±2% RH  
Duration 1000 hours

#### 5.6 Load Test

Power (Nom) 1.5 Vrms, 30ms ON, 470ms OFF  
Input Signal 235Hz sine wave  
Duration 1000 hours

#### 5.7 Drop Test

Fix onto the 200g, 6000 series aluminum alloy carrier and drop on 10mm thick wooden board

Height 1m  
Times 1 time for each direction  
Direction ±X, ±Y, ±Z

### PERFORMANCE REQUIREMENTS AFTER RELIABILITY TEST:

- 1) Acceleration: ≥0.8G at 100g load in middle, 1.5Vrms
- 2) RT (Rise Time): <70ms at 100g load in middle, 1.5Vrms, 235Hz
- 3) BT (Break Time): <110ms at 100g load in middle, 1.5Vrms, 235Hz

**Notice:** Before the tests, it should work normally for 1 hour; after the test, it should be placed at room temperature for at least 4 hours to test its performance.

DESIGNED BY	Rabea Richter	DATE	2021.09.09	PART NO.	LRA 12235L A	INDEX	A
RELEASED BY	Anouschka Esselun	DATE	2021.09.14				
CHANGED BY	Rabea Richter	DATE	2023.05.12				
DRAWING NO.	444484814						

## LRA 12235L A

LINEAR RESONANT ACTUATOR

### 6. PACKING

#### 6.1 PACKING QUANTITY

150pcs per tray

11 trays per carton

1650pcs per carton in total

Carton Size: 35x25x19cm

The first layer is a cover plate

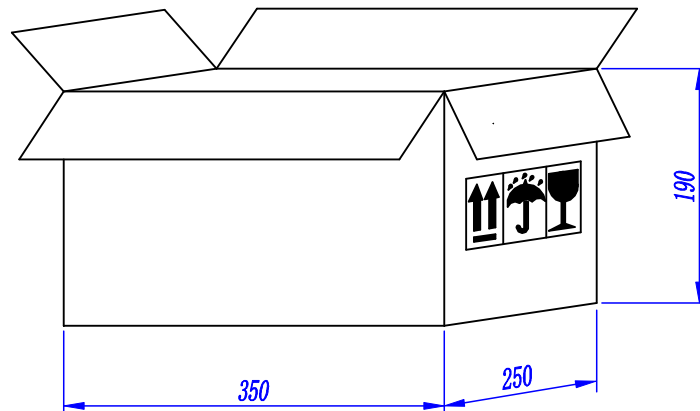
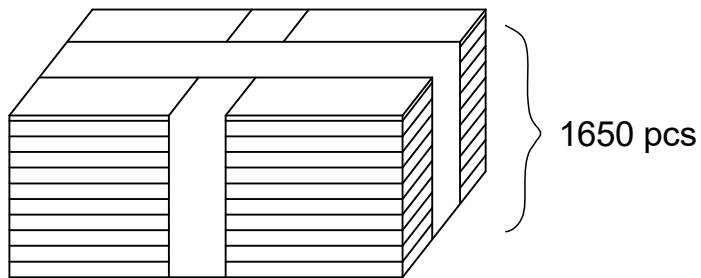
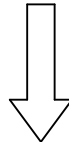
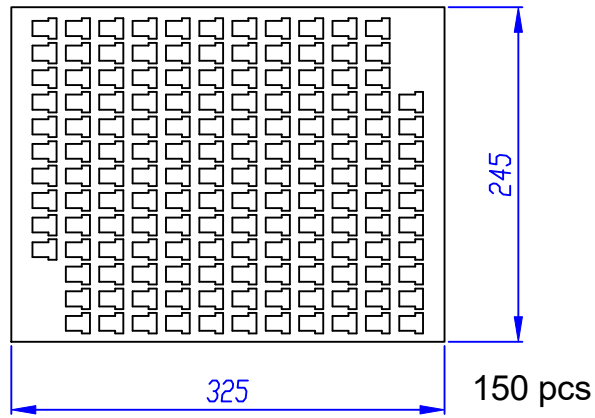

DESIGNED BY	Rabea Richter	DATE	2021.09.09	PART NO.	INDEX
RELEASED BY	Anouschka Esselun	DATE	2021.09.14	LRA 12235L A	A
CHANGED BY	Rabea Richter	DATE	2023.05.12		
DRAWING NO.	444484814				

**7. NOTICE**

**7.1 The products mustn't be washed**

**7.2 Structural and component changes**

The structure and components of the product can be modified to improve the quality of the product without changing the size and performance requirements.

**7.3 Storage Condition**

The products should be stored in a room, where the temperature/humidity is stable. And avoid such places where there are large temperature changes. Please store the products at the following conditions:

Temperature: -10 to + 40 C Humidity: 15 to 85% R.H.

**7.4 Expire Date on Storage**

Expire date (Shelf life) of the products is six months after delivery under the conditions of a sealed and an unopened package.

Please use the products within six months after delivery.

If you store the products for a long time (more than six months), use them carefully, because the products may be degraded in the solderability and/or rusty. Please confirm solderability and characteristics for the products regularly.

**7.5 Notice on Product Storage**

(1) Please do not store the products in a chemical atmosphere (Acids, Alkali, Bases, Organic gas, Sulfides and so on), because the characteristics may be reduced in quality, and/or be degraded in the solderability due to the storage in a chemical atmosphere.

(2) Please use the products immediately after the package is opened, because the characteristics may be reduced in quality, and/or be degraded in the solderability due to storage under the poor condition.

**7.5 Rated and Max Input Voltage**

**Rated Voltage**

Rated input voltage is the maximum (limit) value which can be put into the component intentionally. If the actual input voltage to the component keeps exceeding the Rated Input Voltage, it will damage the component's acoustic performances and reliability. In the worst case, the component will get broken and emit no sound.

**Max Input Voltage**

Max Input Voltage is the maximum (limit) value for unexpected input voltage which is caused in the customer's circuit like surge voltage.

If the actual input voltage to the component keeps exceeding the maximum input voltage, it will break the component and cause no sound in a short time. Please note that the component will have a risk of getting broken if the unexpected input voltage continues.

The value of input voltage is set based on the sinusoidal voltage in the normal speaker use. If the special signal is put into the component, the values of rated and max input voltage will be different. Please make a well-investigation at your laboratory in case of the special signal input.

<b>DESIGNED BY</b>	Rabea Richter	<b>DATE</b>	2021.09.09	<b>PART NO.</b>	<b>LRA 12235L A</b>	<b>INDEX</b>
<b>RELEASED BY</b>	Anouschka Esselun	<b>DATE</b>	2021.09.14			
<b>CHANGED BY</b>	Rabea Richter	<b>DATE</b>	2023.05.12			
<b>DRAWING NO.</b>	444484814					<b>A</b>

**8. HISTORY CHANGE RECORD**

REV	CHANGE ITEMS		DATE
	BEFORE CHANGE	AFTER CHANGE	
A1	Rated Voltage: 1.5Vrms, Operating Voltage: 0.3~1.8Vrms	Rated Voltage: 1.0Vrms, Operating Voltage: 0.3~1.5Vrms	2022.02.02
A2	Rated Voltage: 1.0Vrms Operating Voltage: 0.3~1.5Vrms 5.6 Load Test Power (Nom): 1.0 Vrms	Update product picture Rated Voltage: 1.5Vrms Operating Voltage: 0.3~1.8Vrms Remove Noise Characteristics Update Drawing and Part List 5.6 Load Test Power (Nom): 1.0 Vrms Adding Packing Information	2023.05.12

DESIGNED BY	Rabea Richter	DATE	2021.09.09	PART NO.	LRA 12235L A	INDEX	A
RELEASED BY	Anouschka Esselun	DATE	2021.09.14				
CHANGED BY	Rabea Richter	DATE	2023.05.12				
DRAWING NO.	444484814						